



# Viron eVo Series Pool & Spa Heater

**ASTRAL**POOL 

## INSTALLATION AND OPERATING INSTRUCTIONS



### **Rainbow Pool Products**

PO Box 2388, Mansfield Qld 4122

Telephone STD 61-7-3849 5385

Facsimile STD 61-7-3849 5384

Email: [info@rainbowpoolproducts.com.au](mailto:info@rainbowpoolproducts.com.au)

Web: [www.rainbowpoolproducts.com.au](http://www.rainbowpoolproducts.com.au)

# INDEX

---

## Introduction

Introduction .....	3
Notice to Installers .....	3
Safety Rules .....	3

## Operation

Lighting Instructions .....	4
Operating Instructions .....	4
Turning Gas Off .....	4
Chemical Balance .....	4
Corrosion Prevention in Heaters .....	5
Digital Thermostat Operation .....	5
Display symbol Indication .....	6

## Maintenance

Maintenance Instructions .....	7
Winter Operation .....	7

## Installation

Installation Instructions .....	7
Flow Rates .....	7
Water Connections .....	7
Plumbing Diagram .....	8
Heater Dimensions .....	8
Indoor Installation .....	9
.....	10
.....	11
Clearances .....	11
Electrical Connection .....	11
Gas Connection .....	12
Pressure Switch Adjustment .....	12
.....	13
Testing Inlet Pressure .....	13
Condensate drain .....	14

## Burner Performance Details

Burner Performance .....	15
--------------------------	----

## Troubleshooting

Fault Finding and Remedies .....	16
----------------------------------	----

## Gas Pipe Sizing

Gas Pipe Sizing Tables .....	16
------------------------------	----

## Wiring diagram

Viron Series Wiring Diagram .....	17
.....	18

## Warranty

Terms and Conditions .....	19
----------------------------	----

## INTRODUCTION

---

Congratulations on your purchase of a Viron Pool and Spa Heater by Astral Pool. Proper installation and service of your new heating system and correct chemical maintenance of the water will ensure years of enjoyment. The Viron Series Heater is a compact lightweight and highly efficient gas fired pool and spa heater. It is equipped with features that take advantage of new technology developed exclusively by AstralPool, to provide one of the most efficient and user friendly heaters available. The patent pending heat exchanger will save up to 20% of operating costs over conventional pool & spa heaters, generate condensate which can automatically top up pool water, adjust burner rate to match the heat demand of your pool & spa and is approved with reduced clearances to save on installation space.

The Viron can safely be connected to PVC pipe. It requires high water flow rates which help the heater run cooler, giving greater efficiency and long life. In addition, it is equipped with electronic start up and an accurate electronic thermostat to ensure ease of use and accurate temperature control. The electronic display tells at a glance the operational status of the heater.

### Note:

The appliance is not intended for use by young children or infirm person without supervision. Please ensure that young children are supervised to ensure that they do not play with the appliance.

## NOTICE TO INSTALLERS

---

This appliance must be installed by an authorized person.

This appliance must be installed in accordance with the installation instructions, local gas fitting regulations, Standards Australia Installation Code AS/NZ 5601 and any other relevant statutory authorities.

Refer to data plate for details of gas type, gas consumption and burner pressure.

 **WARNING:** Electrical maintenance and repairs of this equipment must only be done by qualified persons in accordance with Australian and state regulations.

## SAFETY RULES

---

1. Spa or hot tub water temperature should never exceed 40°C.
2. Drinking of alcoholic beverages before or during spa or hot tub use can cause drowsiness which could lead to unconsciousness and subsequently result in drowning.
3. Pregnant women beware! Soaking in water above 38°C can cause foetal damage during the first three months of pregnancy.
4. Before entering the spa or hot tub, the user should check the water temperature with an accurate thermometer, spa or hot tub thermostats may err in regulating water temperatures by as much as 2°C.
5. Persons with a medical history of heart disease, circulatory problems, diabetes or blood pressure problems should obtain their physician's advice before using spas or hot tubs.
6. Persons taking medications which induce drowsiness, such as tranquillisers, antihistamines or anticoagulants, should not use spas or hot tubs.

 **WARNING!** Should overheating occur or the gas supply fail to shut off, turn off the manual gas control valve to the appliance. Do not use this heater if any part has been under water.

## FOR YOUR SAFETY – READ BEFORE LIGHTING

---

This appliance is equipped with an ignition device which automatically lights the burner. Do not try to light the burner by hand.

BEFORE OPERATING smell all around the appliance area for gas. Be sure to smell next to the floor because some gas is heavier than air and will settle on the floor.

 **WHAT TO DO IF YOU SMELL GAS.** Do not try to light any appliance. Do not touch any electrical switch. Do not use any telephone in your building. Immediately call your gas supplier from a neighbour's house.

 **DO NOT PLACE ARTICLES ON OR AGAINST THIS APPLIANCE**

 **DO NOT USE OR STORE FLAMMABLE MATERIALS NEAR THIS APPLIANCE**

 **DO NOT SPRAY AEROSOLS IN THE VICINITY OF THIS APPLIANCE WHILE IT IS IN OPERATION.**

 **NOTE – Servicing shall be carried out only by authorized personnel.**

## OPERATING INSTRUCTIONS

---

-  **STOP!** Read the safety information above.
- Turn off electric power to appliance.
- This appliance is equipped with an ignition device which automatically lights the burner. Do not try to light the burner by hand.
- Wait five minutes to clear out any gas. If you then smell gas, **STOP!** Refer to instructions above.
- Turn filtration pump on.
- Turn on power to the heater and press the pool/spa button to select pool or spa mode.
- Set thermostat to desired setting and the ON/OFF switch to turn the heater ON.
- The heater will ignite in around 40 seconds.
- If the appliance will not operate, turn heater power supply off. Repeat instructions 5 to 7 above. If the appliance still does not ignite, call your service technician.

## TO TURN GAS OFF TO APPLIANCE

---

- Turn off all electrical power to the appliance.
- Turn off gas tap in gas line prior to heater.

## CHEMICAL BALANCE

---

 It is imperative that correct chemical balance be maintained in your pool and spa water, otherwise corrosion of your heater may occur. **Corrosion of the heat exchanger voids warranty.** Your local pool shop specialist or spa retailer can advise correct chemical balance. Your water should be checked and maintained regularly by a pool water professional. As a guide the following parameters may be used.

pH	7.6 to 7.8
Total Alkalinity	80 to 120 ppm
Calcium Hardness	150 to 250 ppm
Salinity	4000ppm max. Excessive salt can damage your heater.

You should test your water chemical balance at least on a weekly basis.

Excessive sanitiser can damage your heater. Chlorine should not exceed 3 ppm and bromine should not exceed 5 ppm. Salt chlorinators, especially when used on spa pools or indoor or covered pools, can easily produce excessive chlorine levels which will damage the heater internals.

## CORROSION PREVENTION IN HEATERS

---

All pool and spa heaters use copper or copper nickel to make their heat exchangers as it is the most efficient material in transferring heat from the combustion chamber into the water. The typical life expectancy of a well maintained pool/spa heater is between 5 and 12 years.

The addition of sanitisers (Chlorine, Bromine etc) and other water balancing and conditioning chemicals can increase the rate of wear and tear on the heat exchanger and associated parts in your heater.

There are three most common reasons for heat exchanger corrosion which can be avoided with a little care and attention.

1. **Excessive Sanitiser.** This means too much Chlorine or Bromine in the water. Be careful, if the level of Chlorine or Bromine is excessively high your test kit (and the pool shops) may not read accurately or indeed may show a nil reading. Any time a salt chlorinator is operating for extended periods, (when heating the swimming pool from cold), particularly if the weather is overcast or the pool enclosed or covered, the Chlorine level may exceed normal levels. When heating a Spa Pool, turn the chlorinator down or off for the duration of the heating period.
2. **Out of balance water.** The water balance is a combination of pH, total alkalinity, Calcium hardness and temperature. Balanced water will help prevent corrosion of your heater. Balanced water should be between 7.2 - 7.8 pH.
3. **The addition of acid to lower pH.** Acid must always be added in small quantities and spread over the pool surface evenly, not added in to the skimmer. Do not add a litre at a time, add a cupful each day to lower your pH.

 If you have a **salt chlorinated** INDOOR pool or COVERED pool be very careful of the level of Chlorine being produced. If you use a salt chlorinated spa be very careful of the level of Chlorine as the Chlorinator is usually sized for the pool and therefore should be switched off when heating the spa. Leaving the chlorinator on can raise the chlorine level very rapidly in a small volume of water.

These comments are intended as a guide only and are not definitive answers or recommendations on pool water chemistry. Astral Pool's intention is to provide a little understanding of the potential problems of water chemistry and the dangers of corrosion to heaters (and other pool equipment and fittings).

 YOUR WATER SHOULD BE ADJUSTED & BALANCED PRIOR TO ANY CORRODED PARTS BEING REPLACED.

## DIGITAL THERMOSTAT OPERATION

---

### DESCRIPTION

The sophisticated digital thermostat provides temperature read out, set point temperature, operating status of the heater and any fault conditions.

### TEMPERATURE DISPLAY

The temperature display indicates water temperature in the inlet of the heater. Therefore the pump must be operating for an accurate pool or spa water temperature to be displayed.

Comfortable pool temperature is between 26°C and 30°C. Normal spa temperature is between 36°C and 38°C. To select your desired temperature press the up or down button repeatedly until the desired temperature is reached.

To prevent rapid cycling of the heater, the thermostat has an inbuilt time delay which prevents the heater from turning on for two minutes after the set point has been reached. If the time delay is activated, the symbol "L" will be displayed on the LCD screen on the front of the heater. This is part of normal operation.



Should a fault condition occur, the heater will lock out and prevent further heating. A lock out condition is indicated by the symbols F0 to F9. To reset a lock out condition, turn the power off for five seconds.

When the water temperature is heated to within 1 degree of the thermostat set point, the Viron burner will modulate or turn down so that the set point is accurately maintained and not exceeded. This prevents waste of energy typically associated with on/off burners. In addition, the set point is maintained very accurately, so the when using your spa pool, you will notice very little variation in water temperature.

# DISPLAY SYMBOL INDICATION

---

Under fault conditions the thermostat will display a set of alpha numeric symbols to indicate the status of the heater. The meaning of each symbol and action to be taken are listed as follows:

SYMBOL	MEANING	ACTION
Temp Display	Unit has power.	No action.
F0	Heater locked off, thermistor wire disconnected or water at 0°C (freeze conditions).	If water temperature reads greater than 0°C, phone for service.
F1	Thermostat reads greater than 45°C.	Allow water to cool below 40°C , turn heater off then on again.
F2	Mechanical Hi Limit greater than 45°C. or 55°C	Allow water to cool below 30°C, turn heater off then on again.
F3	Thermistor fault	Phone for Service
F4	N/A	
F5	N/A	
F6	Flue temperature safety device locked out due to over temperature	Phone for Service
F7	Condensate drain blocked	Phone for Service
F8	Heat exchanger sensor fault	Phone for Service
F9	Heat exchanger sensor too hot Greater than 240degC	Phone for Service
L	Heater locked out on time delay for 2 minutes.	No action. Heater will Automatically reset after time delay. time delay.
	Pump operating & sufficient water pressure to operate heater	No action.
	Thermostat calling for heat. Electronic Flame Supervision operating.	No action.
	Burner Operating	No Action

## MAINTENANCE

---

It is recommended that you check the following at least every six months and at the beginning of every swimming season.

1. Examine the flue outlet and panel louvers for blockages. Make sure there are no obstructions to the flow of air to or from the appliance.
2. Keep the heater area clear and free of combustibles and flammable liquids. Chlorine should not be stored in the vicinity of the heater. Chlorine and acid vapours, when drawn through a heater, can rapidly cause corrosion of the heat exchanger.
3. Keep the heater area free from garden refuse and debris. This will help prevent insects nesting in the unit and ensure extended life and reliability of your heater.
4. Have your heater professionally inspected at least every 2 years.

## WINTER OPERATION

---

If the pool won't be used for a month or more, turn the heater off at the main gas isolation valve. For areas where there is no danger of freezing, water should circulate through your heater all year long even though you are not heating your pool.

Where freezing is possible, it is necessary to drain the water from the heater. This may be done by loosening the inlet or outlet barrel union. If the heater is below water level, isolate it from the pool first by closing shut off valves before and after the heater.

 **CAUTION:** If the heater has been drained for freezing conditions, do not turn on until the system is circulating water

## INSTALLATION

---

THIS APPLIANCE MUST BE INSTALLED BY AN AUTHORISED PERSON. Refer to heater data plate for specifications of gas type, gas consumption, burner pressure and water pressure.

This appliance must be installed in accordance with local regulations and Australian Standard Installation Code AS/NZ 5601.

The installer must test the operation of the appliance before leaving.

### FLOW RATES

The Viron Pool Heater requires a minimum of 200 litres per minute flow for 250 models, 250 litres per minute flow for 350 models, 300 litres per minute flow for 450 models and 350 litres per minute for 550 models. The maximum permissible flow rate is 500 litres per minute. For flow rates in excess of 500 litres per minute, an external by-pass valve must be fitted.

### WATER CONNECTIONS

The heater should always be installed after the pump and filter. The water connections are located on the right hand side of the heater. The inlet and outlet are clearly marked. Water connections require 50 mm PVC glue in plumbing.

All automatic sanitising devices must be installed after the heater and in such a way that the sanitiser cannot enter the heater without first mixing with the water in the pool or spa. Sanitisers that are connected prior to the heater will void heater warranty.

A non return valve is not required to be fitted between the filter and the heater.

## PLUMBING DIAGRAM

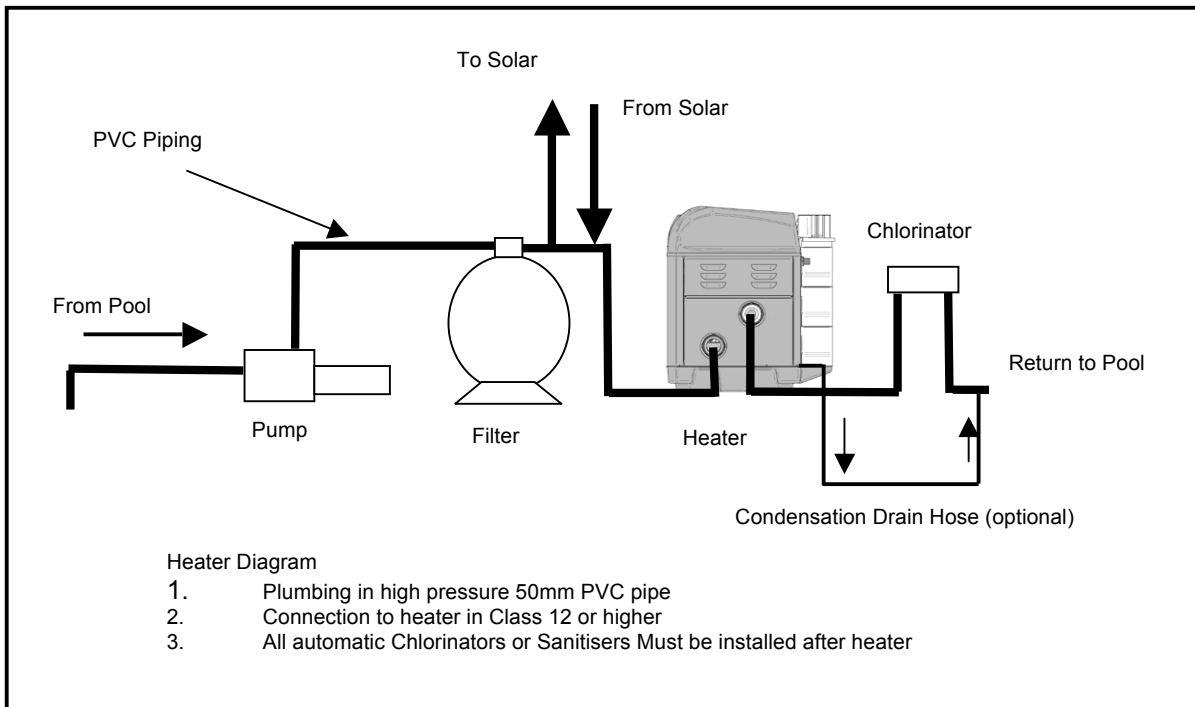

## HEATER DIMENSIONS



Model	Dimension A	Dimension B	Dimension C (Gas Conn)
Viron 250	747mm	285mm	511mm
Viron 350	747mm	285mm	511mm
Viron 450	950mm	395mm	714mm
Viron 550	950mm	395mm	737mm



# INDOOR FLUE INSTALLATION

For indoor installations a purpose built indoor model must be used or the outdoor unit converted by an authorised person. The appliance will be labelled as an indoor model and a 125 mm flue adaptor will be fitted to the appliance. Flue for indoor units must be purchased through AstralPool and can be run up to 8m in length.

Heater must be installed to AS/NZ 5601. Access and suitable working areas must be available to the heater. Flue pipe is supplied with a galvanised sleeved end for the external application and an unsleeved aluminium end for fitment to appliance. The flue pipe can be cut shorter with a knife / saw.

1/ Pre bend the flue where required.

Bends are made by curving the flue pipe around a gentle radius such as a pipe or knee. Do not over bend and kink flue pipe. Keep bends to a minimum and use as large as radius as possible. Minimum internal radius is 250mm.

Bends can be restraightened if required.



2/ Fit flue pipe to appliance (unsleeved end of flue). Insert flue connection fully into flue pipe. Fit hose clamp to connection and tighten.



3/ Form extra bends where required. Care should be taken when forming bends to not create a low point where condensation may collect. Condensation should be able to drain to the heater or out the flue outlet. The flue should be bracketed at intervals of 1 M using standard 125 mm standoff brackets available at most plumbing suppliers.

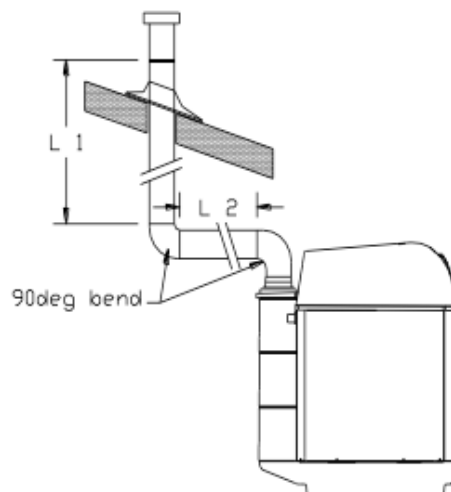

The flue temperature will be approximately 85 degrees C and should be kept at least 25 mm clear of any combustible surface.

#### 4/ Joining flue sections.

Supplied with the flue is a special joiner piece. To join the flues insert a bead of silicon into both ends of the joiner . Push the flue into the end of the joiner piece. Secure the flue with pop rivets. Repeat for the second flue pipe connection.



#### 5/ Rooftop terminations.

All flue exiting the roof must be shielded with the gal cover. Extra lengths of gal can be supplied. Decktite fittings / flashings must be attached to the galvanised flue cover. Brace flue in high wind applications. Locate flue cowl onto reduced end of the gal outer covering / flue pipe. Attach with rivets / screws to hold into place.

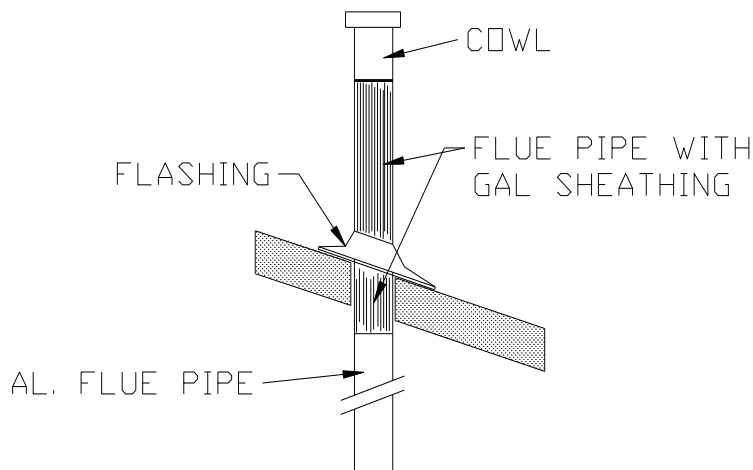

#### 6/ Wall terminations.

Ensure location is suitable as flue gases exit all around cowl and may blow back onto walls, eaves, features causing discolouration or mould and moisture issues. Condensation will occur around the flue exit area and condensation may drip from the flue outlet.

All flues exiting the wall must be shielded with the gal cover. Extra lengths of gal can be supplied. Decktite fittings / flashings / wall exiting covers must be attached to the galvanised flue cover.

For long extensions of flue exiting the wall bracing may be required in high wind applications.

Locate flue cowl onto reduced end of the gal outer covering / flue pipe. Attach with rivets / screws to hold into place. Ensure a drain hole in the cowl is facing down.

The flue pipe must slope slightly towards the cowl for the last horizontal run (approx 2 deg) to allow condensation to drain.

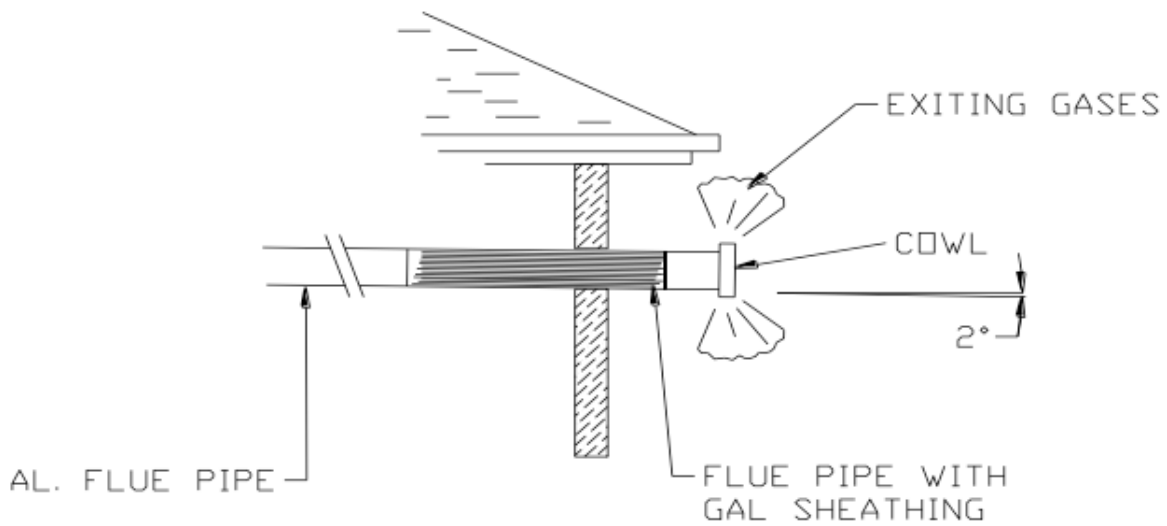

## CLEARANCES

---

Installation clearances must comply with AS/NZ 5601. The heater is approved for installation at reduced clearances as below.

<b>Outdoor Clearances</b> from	combustible surfaces	non combustible surfaces
Front	300mm	300mm
Both sides	300mm	300mm
Rear	300mm	50mm
Above	1000mm	1000mm

<b>Indoor Clearances</b> from	combustible surfaces	non combustible surfaces
Front	300mm	300mm
Both sides	300mm	50mm
Rear	300mm	50mm
Above	500mm	500mm

**Heater must be installed on a fireproof base.**

## VENTILATION

---

When installing the heater indoors, it is imperative that an adequate supply of fresh air is provided for combustion. Failure to provide adequate ventilation voids all warranties and may be a danger to persons or property.

Two permanent openings shall be provided directly to outside. The openings shall be located to ensure the distance between the top of the upper opening and the ceiling of the room or enclosure, and the distance between the bottom of the lower opening and the floor of the room or enclosure does not exceed 5% of the height of the room or enclosure.

The minimum vertical dimension of any free ventilation opening shall be 6 mm.

The minimum free ventilation area provided directly outside by each opening shall be:

MODEL	AREA
Viron 250	57,000 mm <sup>2</sup>
Viron 350	87,000 mm <sup>2</sup>
Viron 450	112,500 mm <sup>2</sup>
Viron 550	147,500 mm <sup>2</sup>

If ventilation provided is obtained from an adjacent room then these areas will increase.

The following diagram is provided as a guide only. All fluing and installation work must be carried out by an authorized person. Fluing must conform to local regulations and to A.G.A. installation code AS/NZ 5601. Care must be taken to provide the correct ventilation and correct fluing materials in close proximity to combustible surfaces.

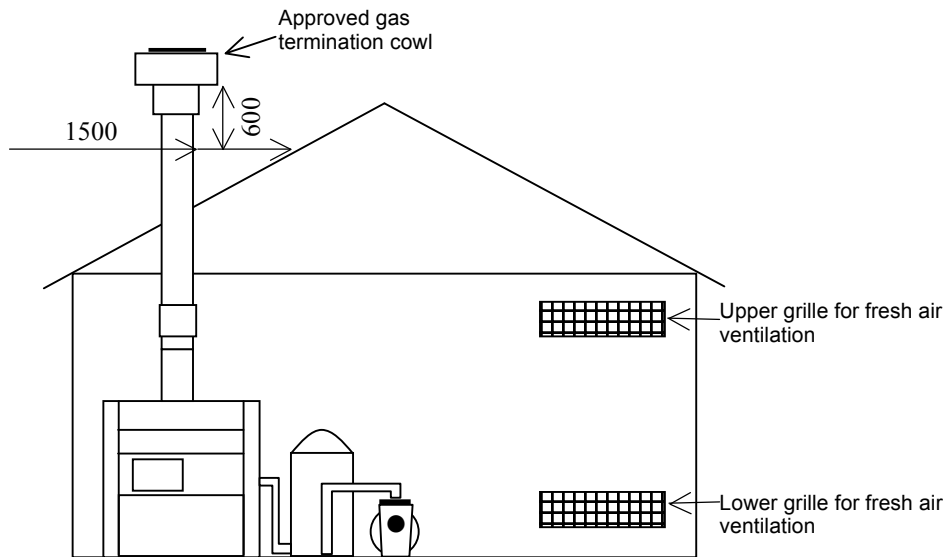

**⚠ Do not install spa blowers in the same room as a gas heater. This is potentially dangerous to spa users.**

**⚠ Do not store chemicals or fuel in the same room as the gas heater. This may cause fire or explosion. When installing in a garage the Viron Series Heater must be installed 450 mm above floor level.**

## ELECTRICAL CONNECTION

---

The heater is supplied with a standard 10 amp 3 pin plug for connection to a 240V 10 amp GPO. All pool or spa equipment connected to mains power should be protected by an RCD circuit breaker.

## GAS CONNECTION

---

250/350/450 models.

The gas connection is on the rear of the heater. A 22mm M.I. connection is provided for gas line connection. An approved manual shut off valve must be installed in the gas fitting line before the heater.

The gas fitting line should be installed by an authorised person and comply with local regulations and Australian Standard code AS/NZ 5601. The gas line from the meter will usually be of a larger size than the gas inlet connection.

The heater gas valve has a built in pressure regulator and 1/8" pressure test point. On starting the heater, a manometer must be used and the supply inlet pressure checked while the heater is running against the heater data plate. Incorrect inlet pressures may void warranty and may result in service charges, should service be required. Gas valves are preset and should only be adjusted by trained Astral Pool technicians.

## PRESSURE SWITCH ADJUSTMENT

---

The Viron Pool Heater incorporates a water pressure switch which allows the burner to operate only when the circulating pump is operating. The pressure switch is designed to operate with the heater installed up to 3 metres above or below the surface level of the pool or spa.

It is imperative that the following be undertaken by the person who is commissioning (first starting) your pool or spa heater. On initial start up of the heater it may be necessary to adjust the water pressure activation switch.

This switch is located behind the top right hand side panel and is screwed into the water manifold. The pressure switch is a safety device, designed to allow operation of the heater only when the circulating pump is on and there is sufficient water flow through the heater. It must shut the heater down immediately the pump is switched off.

### **To check the operation of the switch:**

1. Connect the heater to mains power supply and turn power on. The thermostat should not yet display "θ".
2. Turn on pump. The thermostat should now display "θ".
3. Turn pump off. The thermostat should no longer display "θ".
4. If display does not respond in this way, adjust the pressure switch as detailed below. If display responds correctly, perform a final check with the heater operating – see the section below titled "Starting the heater".

### **To check the operation of the switch:**

1. Connect the heater to mains power supply and turn power on. The thermostat should not yet display "θ".
2. Turn on pump.
3. View the display of the heater to confirm the "θ" has appeared on the LCD display on front of heater.
4. If no symbol is present, slide the toggle up to allow adjustment, then rotate knurled wheel anti clockwise (as viewed from above) until "θ" is displayed.
5. Switch pump off.
6. View LCD display to confirm the "θ" has disappeared.
7. If "θ" symbol is present when pump is OFF or "θ" does not disappear within 1 (one) second of pump turning off, the pressure switch must be adjusted.
8. With Pump turned OFF, turn knurled wheel clockwise to increase the pressure required to activate the switch.
9. Repeat steps 2 to 8 until symbol appears and disappears when pump turns on and off.
10. When the pressure switch is correctly set, slide the toggle down to lock the knurled wheel in position.
11. If pressure switch cannot be made to activate heater when pump is turned on and off, a flow switch may need to be purchased and fitted. Contact your local AstralPool office for details.

**⚠ WARNING:** If the pressure switch cannot be adjusted correctly, DO NOT OPERATE THE HEATER, contact Astral or an Authorised Service Agent for advice.

1. Perform a final check with the heater operating.- See the section below titled “Starting the heater”.

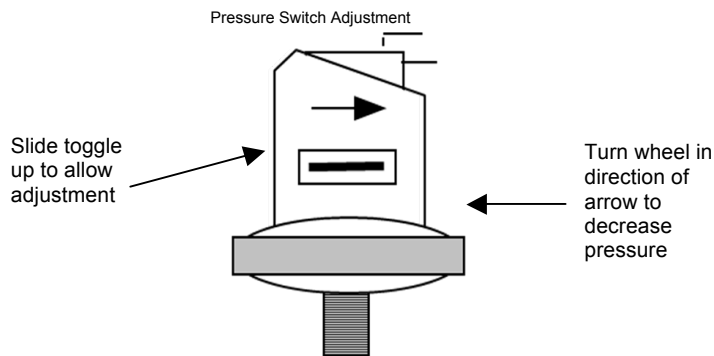

It is imperative that the heater is installed so that it does not operate when the circulating pump stops. Recommended methods to achieve this are:

- a. Correct adjustment of internal pressure switch. Ensure heater does not turn on two or three minutes after circulating pump is turned off.
- b. Installation of an external flow switch may be preferred under certain installations where internal pressure switch does not turn heater off when circulator stops.



## Rainbow Pool Products

PO Box 2388, Mansfield Qld 4122

Telephone STD 61-7-3849 5385

Facsimile STD 61-7-3849 5384

Email: [info@rainbowpoolproducts.com.au](mailto:info@rainbowpoolproducts.com.au)

Web: [www.rainbowpoolproducts.com.au](http://www.rainbowpoolproducts.com.au)

## TESTING INLET PRESSURE

---

1. **Note – gas pressure must be measured when unit is operating.**
2. Set thermostat to “OFF”.
3. Remove top cover (2 screws at rear of heater, remove L/H side panel, remove front 2 screws hidden inside side panel area)
4. Remove electrical enclosure screws and hinge cover forward.
5. Loosen screw from 1/8” brass test point located on inlet side of gas valve
6. Connect manometer tube to test point
7. Set thermostat to “ON” and wait for burner to ignite
8. Once burner has ignited, the manometer must indicate the nominal inlet pressure listed below.
9. Adjust inline pressure to meet minimum required pressure at main gas regulator. Do not adjust gas valve settings..
10. Tighten test point screw.
11. Refit covers.

### Required Inlet Static gas pressure (ie: when heater not operating)

Natural Gas	1.13 kPa minimum	5 kPa maximum
Propane	2.75 kPa minimum	5 kPa maximum

## PERFORMANCE DETAILS

---

### TO CHECK BURNER PERFORMANCE – Must be performed with a combustion analyser

1. Turn off power supply to pump and heater.
2. Turn off gas supply to unit.,
3. Remove top cover.
4. Remove electrical enclosure screws and hinge electrical cover forward.
5. Setup gas combustion analyser
6. Set up manometer to inlet side of gas valve.
7. Adjust gas rate screw 4 turns anticlockwise.
8. Turn on gas supply.
9. Turn on power to heater.
10. Start heater
11. Ensure heater is running at full fan rate.
12. Check inlet gas pressure is between max and min settings.
13. While heater is running adjust gas ratio screw to achieve a CO level of between 30ppm to 60 ppm for Natural Gas models and between 50ppm and 150ppm for model 250 LPG
14. Check meter gas usage rate to ensure gas rate is as specified. Gas rate must be within +/-5% of nominal rate.
15. Remove manometer and tighten test point.
16. Remove analyser.
17. Refit electrical cover.
18. Refit cover.

### Gas inlet pressures (all models) during burner operation on high fire

Natural Gas	1.13 kPa
Propane	2.75 kPa

### CO level (all models)

Natural Gas	30ppm minimum	60ppm maximum
Propane	50ppm minimum	150ppm maximum

### Gas inlet rates

Viron 250	Natural gas & Propane 190mj/hr
Viron 350	Natural gas 290mj/hr, Propane 280mj/h
Viron 450	Natural gas & Propane 375mj/hr
Viron 550	Natural gas & Propane 490mj/hr

## CONDENSATE DRAIN

---

The Viron heater is a highly efficient gas appliance capable of generating 12 litres an hour of condensation. Suitable drainage provision must be provided to ensure condensation does not build up in the heater or flood damage surrounding areas. Do not raise the drain hose higher than the exit point of the appliance.

Alternatively, the condensate can be used to replenish or “top up” your pool water. A condensate recovery kit can be purchased from your local Astral Pool equipment supplier.

The condensate has a pH of approximately 6.8. Most chlorines and sanitisers used for pool water disinfection will increase the pool water pH over a period of time, so an additional advantage of the condensate produced by your Viron Heater is that the low pH will counter balance the high pH of the disinfectant used in most pools.

**IMPORTANT:** Chlorines, disinfectants and sanitisers usually require a narrow bank of pH in which to work effectively. Ensure you check the pH of your pool or spa weekly, and adjust as necessary.

## ELECTRONIC FLOW RESPONSE

---

The Viron heater is capable of being linked to the AstralPool series of Viron multispeed pumps via RJ12 cabling (not supplied). By taking advantage of this connection, you can ensure your heater will operate at peak performance and last for many years.

Connection to the Viron heater is via the RJ12 socket located inside the access panel where the water connections are made to the heater. Connections for the pump are made through the rear of the electrical box.

In connecting your Viron Pool and Spa heater to your Viron multispeed pump, the two appliances will communicate to adjust speeds on the pump based on the demands of the heater.

- If the heater is in the ON position pump will operate at a minimum of “Medium” speed
- If the heater is operating (burner symbol on screen) the pump will operate on “High” speed
- When the heater shuts off the pump will return to the default speed set on the pump

If you require assistance with this connection, please contact your local AstralPool Australia branch for further advice.



### **Rainbow Pool Products**

PO Box 2388, Mansfield Qld 4122

Telephone STD 61-7-3849 5385

Facsimile STD 61-7-3849 5384

Email: [info@rainbowpoolproducts.com.au](mailto:info@rainbowpoolproducts.com.au)

Web: [www.rainbowpoolproducts.com.au](http://www.rainbowpoolproducts.com.au)



## TROUBLESHOOTING

<b>HEATER WILL NOT LIGHT</b>	
<b>Possible cause</b>	<b>Remedy</b>
No display	Check if power to heater is turned on
Pump not running	Start pump
Pump air locked	Check for leaks
Filter dirty	Clean filter
Pump strainer basket clogged	Clean strainer
Thermostat turned off	Turn on
Set temperature lower than water temperature	Increase set temperature
Water too hot-fault condition displayed	Refer to fault indication table
Gas turned off	Turn gas cock on
Heater in a Fault condition	Refer to fault indication table
<b>HEATER SHORT CYCLING (RAPID ON AND OFF OPERATION)</b>	
<b>Possible cause</b>	<b>Remedy</b>
Insufficient water flow	Clean filter and pump strainer
<b>HEATER MAKING KNOCKING NOISES</b>	
<b>Possible cause</b>	<b>Remedy</b>
Low water flow	Check pump condition
Heater operating after pump has shut off	Shut off gas supply and call for service
Heat exchanger scaled	Shut off gas supply and call for service

### Ignition Module LED Flash Code

<b>LED Flash Code (Long flashes– short flashes)</b>	<b>Description</b>
<b>The following codes may occur during startup</b>	
0-2	Normal Operation – Start Up Delay
1-0	Normal Operation
1-1	Flame failure detected
1-2	Waiting for main pressure switch
1-3	Waiting for second pressure switch
1-4	Waiting for flame sense to go OFF
1-5	Purge operation in progress (pre purge, inter purge or post purge)
1-8	Waiting for fan tach feedback signal to be within acceptance window (module option)
<b>The following codes are invoked as a result of a lockout condition</b>	
2-1	Maximum retries exceeded
2-2	Lockout due to flame failure
2-3, 2-4, 2-5	Hardware failure on module output(s). Possible hardware failure in module
2-6	Hardware failure on flame sensing circuit.
2-7	Hardware failure in module
2-8	Combustion Fan timeout (where fitted)
2-9	Vent Switch lockout (where fitted)
<b>The following codes are invoked as a result of a lockout condition / hardware fault</b>	
3-1	Lockout due to main pressure switch opening (where fitted)
3-2	Lockout due to second pressure switch opening (where fitted)
3-3	Lockout due to fan tach feedback signal failing (where fitted)
3-4	Lockout due to internal fault (software error).
3-5	Lockout due to internal fault (EEPROM error)
3-6	Lockout due to internal fault (microcontroller communications error)

If the heater cannot be made to perform correctly, please contact the Astral Pool office closest to you.

## GAS PIPE SIZING TABLES

1.13 kPa gas meter pressure					
Some areas of VICTORIA					
Maximum run of copper pipe with average number of fittings					
Model	20 mm	25 mm	32 mm	40 mm	50 mm
VIRON 250	2 m	8 m	30 m	75 m	320 m
VIRON 350	-	4 m	14 m	35 m	140 m
VIRON 450	-	3 m	8 m	20 m	90 m
VIRON 550	-	1	6 m	14 m	60 m

1.25 kPa gas meter pressure					
S.A., W.A., some areas N.S.W.					
Maximum run of copper pipe with average number of fittings					
Model	20 mm	25 mm	32 mm	40 mm	50 mm
VIRON 250	6 m	25 m	90 m	240 m	320 m
VIRON 350	3 m	14 m	45 m	110 m	320 m
VIRON 450	2 m	8 m	25 m	70 m	300 m
VIRON 550	-	6 m	18 m	45 m	200 m

2.75 kPa gas meter pressure				
N.S.W. some areas, Victoria some areas, Qld some areas				
Maximum run of copper pipe with average number of fittings				
Model	15 mm	20 mm	25 mm	32 mm
VIRON 250	4 m	40 m	160 m	320+ m
VIRON 350	2 m	20 m	85 m	280 m
VIRON 450	-	12 m	50 m	160 m
VIRON 550	-	8 m	35 m	100 m

Gas Pipe Sizing Tables are indicative only. All pipe sizing should be calculated by an authorised person.



### Rainbow Pool Products

PO Box 2388, Mansfield Qld 4122

Telephone STD 61-7-3849 5385

Facsimile STD 61-7-3849 5384

Email: [info@rainbowpoolproducts.com.au](mailto:info@rainbowpoolproducts.com.au)

Web: [www.rainbowpoolproducts.com.au](http://www.rainbowpoolproducts.com.au)

# VIRON DSI MODELS WIRING DIAGRAM

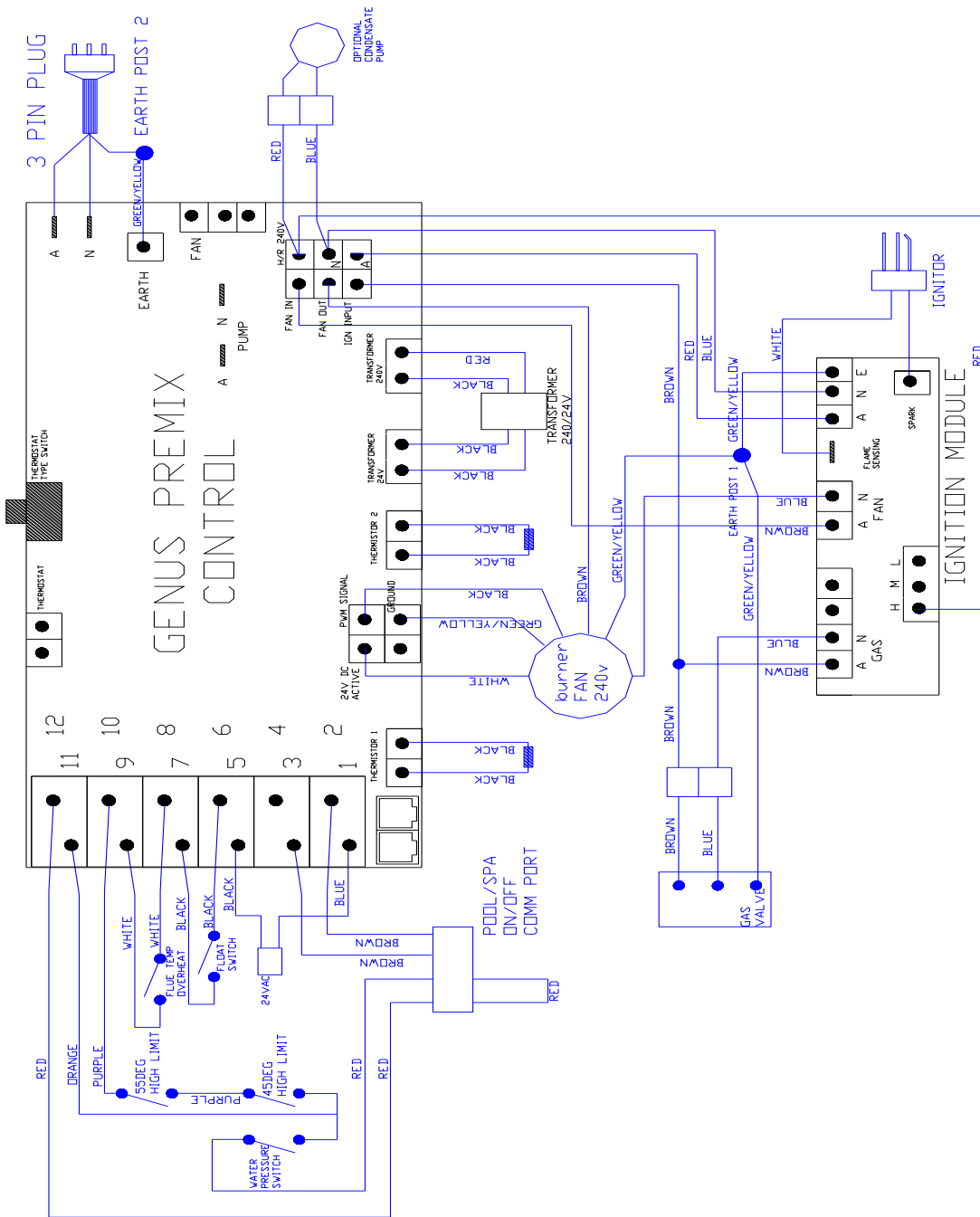

# VIRON PILOT MODELS WIRING DIAGRAM

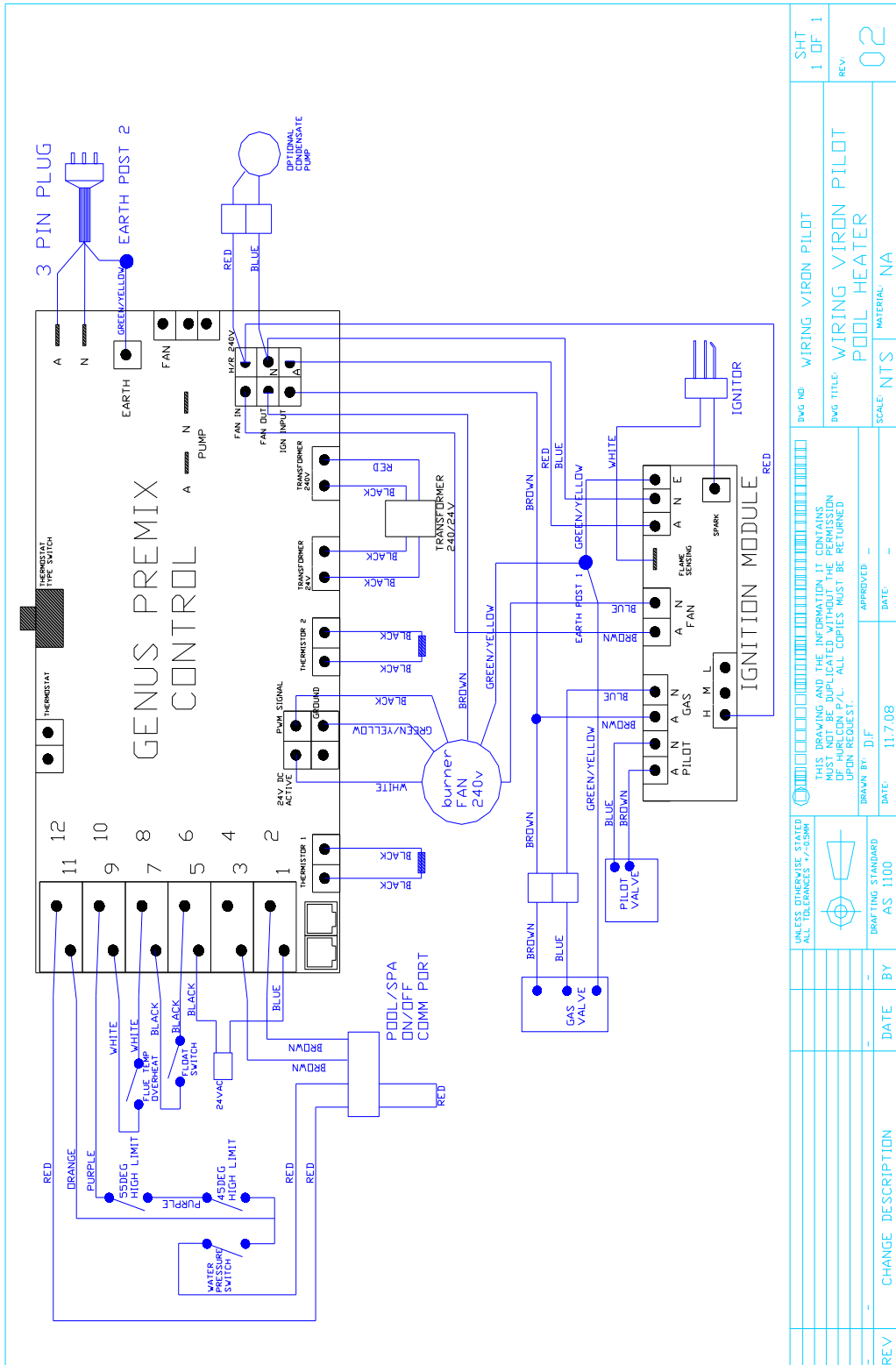

REV	CHANGE DESCRIPTION	DATE	BY
-	-	-	-
<p>UNLESS OTHERWISE STATED ALL TOLERANCES 1/16" - 0.5MM</p> <p>THIS DRAWING AND THE INFORMATION IT CONTAINS MUST NOT BE DUPLICATED WITHOUT THE PERMISSION OF THE ORIGINAL AUTHOR. ALL COPIES MUST BE RETURNED UPON REQUEST.</p> <p>DRAWN BY: DJF      DATE: 11.7.08      APPROVED: _____      DATE: _____</p> <p>DRAFTING STANDARD: AS 1100</p>			
DWG NO:	WIRING VIRON PILOT	SHT 1 OF 1	
DWG TITLE:	WIRING VIRON PILOT POOL HEATER	REV: 02	
SCALE:	NTS	MATERIAL:	NA

## Maintenance of your heater

**Maintenance Schedule:** Your new product incorporates moving parts and withstands high velocity water with chemicals in it. Some of these parts will wear in the normal course of use and require regular checks and maintenance. Performing these checks and maintenance will identify parts that have worn and require repair/replacement before further serious damage is sustained. A small amount of regular care and attention to your pool equipment will help ensure long life and trouble free performance.

Timing	Maintenance Check	Service action (if required)
Monthly	Operate heater for 15 min to clear residues and ensure correct operation	Start circulation pump and turn heater on, leaving to run for a few minutes. This will clear flue passages and keep components working properly
Three Monthly	Check inlet/outlet o'rings for leaks	Isolate Pump, turn power off, clean and grease O rings or replace if necessary
Three Monthly	Check surroundings for leaves, debris and flooding	Remove debris from around the base of the heater and rectify if any flooding. Clear vegetation from around the flue
Annually	Check gas pressures  Check Burner, pilots and ignition systems	Call Service technician to perform annual gas checks and routine maintenance Must be completed by an authorised person

**Important note:** Regular maintenance is important to ensure long life and trouble free performance of your pool equipment. If unable to perform the maintenance yourself, contact your local AstralPool office who will arrange a trained service technician to perform the maintenance for you.

Record your Equipment details here for quick reference:

Model No.: \_\_\_\_\_

Serial No.: \_\_\_\_\_



### Rainbow Pool Products

PO Box 2388, Mansfield Qld 4122

Telephone STD 61-7-3849 5385

Facsimile STD 61-7-3849 5384

Email: [info@rainbowpoolproducts.com.au](mailto:info@rainbowpoolproducts.com.au)

Web: [www.rainbowpoolproducts.com.au](http://www.rainbowpoolproducts.com.au)



## WARRANTY TERMS AND CONDITIONS

---

AstralPool Australia Pty Ltd (ABN 97 007 284 504) ("AstralPool") provides the following warranty in relation to its Viron series gas pool & spa heaters.

*Our goods come with guarantees that cannot be excluded under the Australian Consumer Law. You are entitled to a replacement or refund for a major failure and for compensation for any other reasonably foreseeable loss or damage. You are also entitled to have the goods repaired or replaced if the goods fail to be of acceptable quality and the failure does not amount to a major failure.*

The benefits of this warranty are in addition to any rights and remedies imposed by Australian state and federal legislation that cannot be excluded. Nothing in this warranty is to be interpreted as excluding, restricting or modifying any state or federal legislation applicable to the supply of goods and services which cannot be excluded, restricted or modified.

### WARRANTY

AstralPool warrants that, subject to the exclusions and limitations below, the product will be free from defects in materials and workmanship during the warranty period. The warranty periods are set out below and commence 30 days after the date of purchase (to allow for installation). The warranty period may vary for different parts of the Product.

Parts	Warranty Period
Cabinet, refractory insulation and combustion chamber	5 years
Components such as gas valve, thermostat, pilot, wiring, burner, gaskets	2 years
Heat exchanger, inlet and return water headers	12 months

If a defect appears in the product before the end of the warranty period and AstralPool finds the product to be defective in materials or workmanship, AstralPool will, in its sole discretion, either:

- (a) replace or repair the product or the defective part of the product free of charge; or
- (b) cause the product or the defective part of the product to be replaced or repaired by an authorised AstralPool Service Agent free of charge.

AstralPool reserves the right to replace defective parts of the product with parts and components of similar quality, grade and composition where an identical part or component is not available.

Goods presented for repair may be replaced by refurbished goods of the same type rather than being repaired. Refurbished parts may be used to repair the goods.

### WARRANTY CLAIMS

1. If a fault covered by warranty occurs, the customer must first contact AstralPool at the contact address listed below, or an Authorised AstralPool Service Agent.
2. Any warranty claim must be accompanied by:
  - (a) proof of purchase;
  - (b) full details of the alleged defect; and
  - (c) appropriate documentation (such as historical and maintenance records).
3. The customer must make the product available to AstralPool or its authorised AstralPool service agent for inspection and testing. AstralPool or its authorised AstralPool service agent will attend the premises where the product is installed for inspection and testing. If the product is installed:
  - (a) outside a capital city metropolitan area; and
  - (b) is not within a 20 km radius of an Authorised AstralPool Service Agent;

then the customer may have to pay a travel fee.

4. If such inspection and testing finds no defect in the product, the customer must pay AstralPool's usual costs of service work and testing. If such inspection and testing finds a defect that is not covered by this warranty, the customer must pay AstralPool's usual costs of service work plus any parts and labour required to repair the Product, unless recoverable from AstralPool on the failure of any statutory guarantee under the ACL.

### **Exclusions**

The warranty will not apply where:

- (a) the customer is in breach of the Terms and Conditions of Sale;
- (b) the Product was used for a purpose other than one it was intended for;
- (c) the Product was repaired, modified or altered by any person other than AstralPool;
- (d) the Product has not been installed, maintained and/or operated in complete compliance with the installation and operating instructions and any instructions by AstralPool;
- (e) the Product has been subject to accident, negligence, alteration, abuse or misuse.

The warranty does not extend to:

- a) normal wear and tear;
- b) weather and other environmental conditions including but not limited to storm, flood, and/or heat wave damage; or
- c) service and maintenance items.

Examples of exclusions include but are not limited to:

- Incorrect/insufficient gas supply
- Incorrect/insufficient ventilation
- Incorrect water balance

### **Commercial Installations**

On commercial installations, such as health clubs, motels/hotels and hydrotherapy facilities, the warranty is limited to parts and in field labour (within capital city metropolitan areas or 20 km radius of Authorised AstralPool Service Agents) for a period of 12 months from the date of purchase plus 30 days to allow for installation.

### **LIMITATIONS**

AstralPool makes no express warranties or representations other than set out in this warranty.

The repair or replacement of the Product or part of the Product is the absolute limit of AstralPool's liability under this express warranty.



## **Rainbow Pool Products**

PO Box 2388, Mansfield Qld 4122

Telephone STD 61-7-3849 5385

Facsimile STD 61-7-3849 5384

Email: [info@rainbowpoolproducts.com.au](mailto:info@rainbowpoolproducts.com.au)

Web: [www.rainbowpoolproducts.com.au](http://www.rainbowpoolproducts.com.au)